



HIGH PERFORMANCE VHF/UHF ANTENNA for Home Use

Reception Channels	European Standard	ch.5-12, 21-58
	American Standard	ch.7-13, 14-63
	Chinese Standard	ch.6-12, 13-45

VU144LK2

INSTRUCTION MANUAL

For Horizontal Polarization only

75 Ω

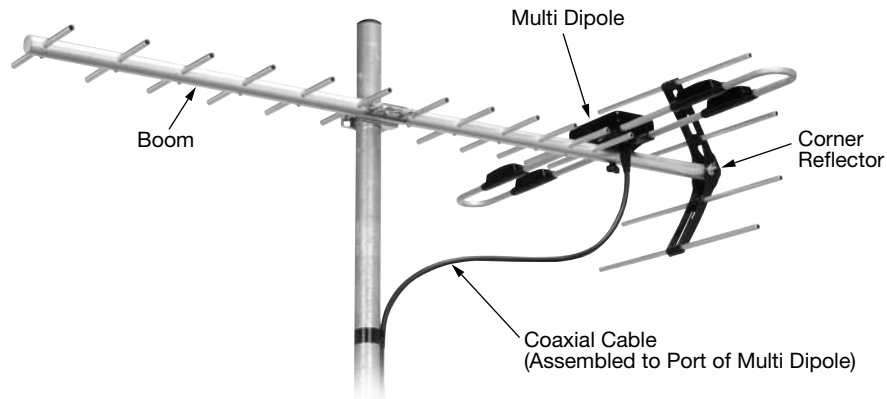

Corner Reflector

MASPRO's corner reflector reduces double images, and makes clear pictures.

Aluminum Boom

Aluminum boom is light yet sturdy.

Multi Dipole

4 Traps can allow to receive wideband (VHF E ch.5~12, UHF E ch.21~58) with one dipole only.

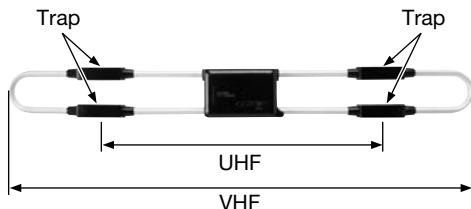

Assembled Coaxial Cable to Multi Dipole already

14m coaxial cable was assembled to multi dipole, which makes installation of antenna easily.

NOTE

Skills and experience are required to install antennas on roofs or other elevated locations. Make sure to consult your installer concerning installation.

Antenna Installation Precautions

- Be very careful to install antenna at the safest spot possible, so that parts of the antenna will not cause injury or property damage if they fall.
- To prevent electric shock accidents, install the antenna as far away as possible from wires (powerlines, high voltage wires, telephone lines) so that it will not come into contact with the wires even if it falls.
- Never attempt installation on rainy or windy days. Be extremely careful also when working under a scorching sun in summer, as the roof can become very hot.
- Take necessary safety measures before installing antenna, e.g. binding the antenna, mounting dipole, and tools to prevent them from dropping.
- Working at elevated locations is extremely dangerous. Take all safety measures possible before installation. When you are on the roof, you may experience vertigo or experience an exaggerated sense of height, your feet may become shaky and your footing unstable. Take special care to avoid slipping.
- Make sure to remove TV and/or Tuner AC plugs from AC wall outlets when you connect 75 Ω coaxial cable from TV and/or Tuner. If plugs remain in outlets, electric shock may occur.
- Do not install the antenna and guy wire by yourself. Make sure that someone, or preferably two or more people, are present to assist you.
- If you hear thunder, do not touch antenna, cable and another accessories to fix them. It may cause shock.
- After a typhoon, check the antenna, mounted dipole, mast, roof mount, and guy wires for any signs of trouble or loosened bolts and nuts. Replace damaged or bent antenna with a new one. If you neglect damaged antenna or leave them without proper maintenance, parts of the antenna and mounting dipole may become damaged and drop, causing physical injury or property damage.
- Be careful not to use a rusty or corroded antenna and mounting bracket. Weak or damaged equipment may loosen and drop, resulting in physical injury or property damage.

Assembly

Check the direction of boom and elements carefully and firmly tighten wing bolt and wing nuts.

Multi Dipole

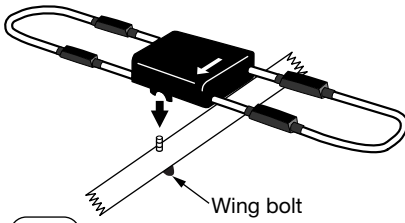

After installing multi dipole along the direction of arrow shown on top of cover to the front direction, then tighten wing bolt up.

NOTE

Install multi dipole as cover upward.

Corner Reflector

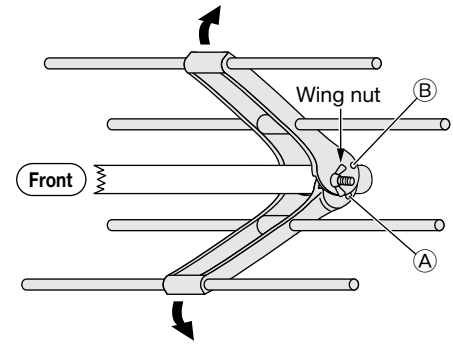

- ① Open folded corner reflector till knobby boss of point A fits into hole of point B, then do not open any more.
- ② Tighten wing nut up.

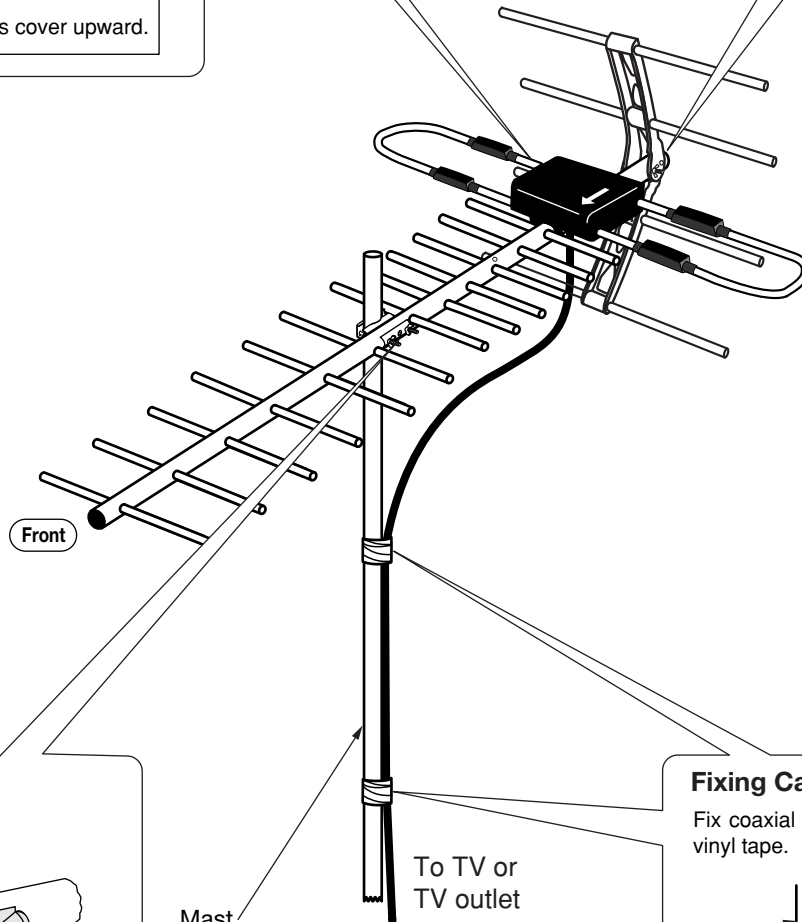

Mast Fixing Clamp

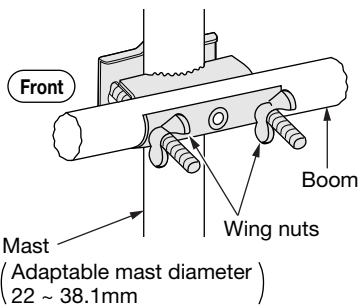

Loosen wing nuts, after passing mast, tighten wing nuts firmly.

Fixing Cable

Fix coaxial cable to the mast with vinyl tape.

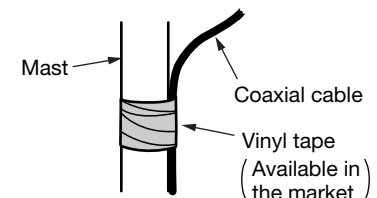

How to Install Another Cable

Cable processing

- If possible, use 5C2V coaxial cable, or other cable which has either equaling or surpassing performance.
- Remove assembled weather boot connected to dipole port, then pass cable through weather boot again. (Process cable tip after getting cable through weather boot.)

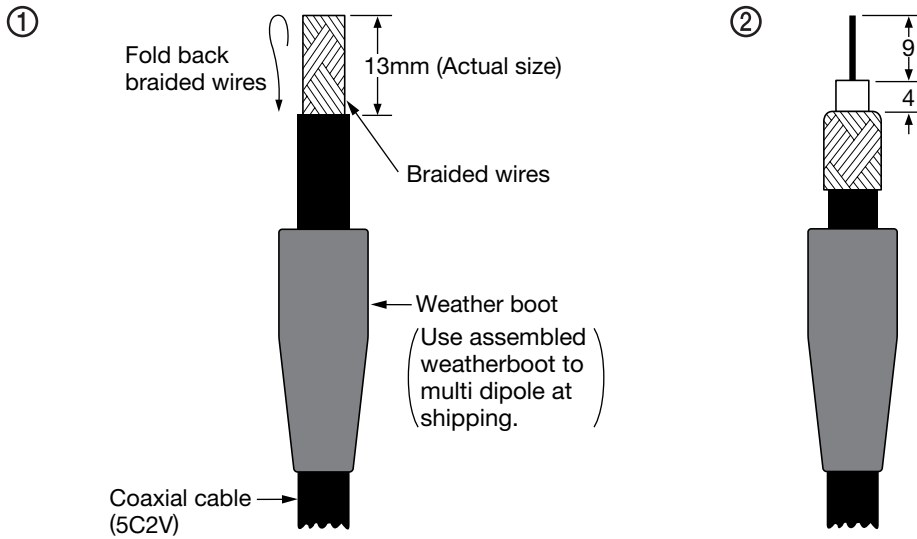

Connection to Multi Dipole

- ① Open the cover of multi dipole, then install coaxial cable.
- ② After installing coaxial cable, close the cover firmly.

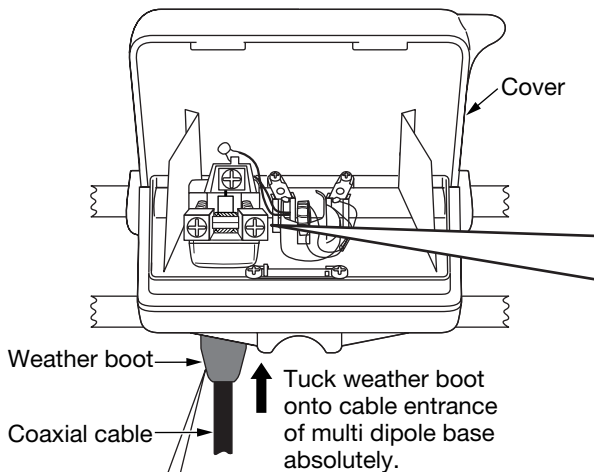

DO NOT bind vinyl tape onto weather boot, rain drops occurs trouble.

- ① Insert center conductor under retainer plate.
- ② Fix the folded outer conductor (braided copper wire) with screw for fixing outer conductor, and tighten it at the torque value below.
- ③ Fix the center conductor of cable with screw for fixing center conductor at the torque value below.

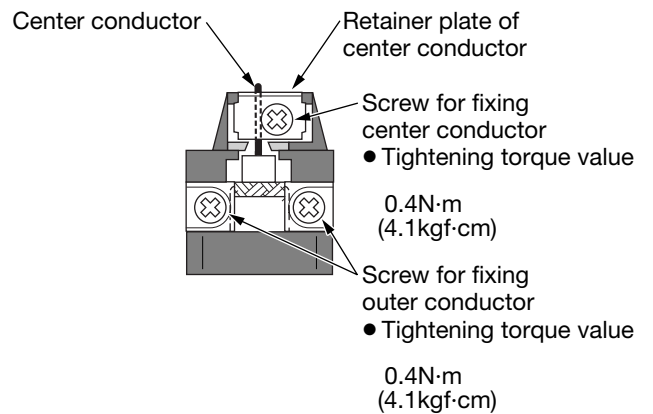

Shut the cover of multi dipole with a snap after connecting cable.

Specifications

MASPRO

Items	Specification	
Reception Channels	E ch.5 - 12 A ch.7 - 13 C ch.6 - 12	E ch.21 - 58 A ch.14 - 63 C ch.13 - 45
Number of Elements	1	14
Impedance	75 Ω	
Gain	⊖ 2 - 1dB	4.5 - 9dB
VSWR (Voltage Standing Wave Ratio)	4.5 or less	3.5 or less
Front-to-Back Ratio	—	10 - 20dB
Half Power Beam Width	65 - 90°	25 - 65°
Adaptable Mast Diameter	22 - 38.1mm	
Dimensions	1030(L) × 650(W) × 250(H) mm	
Weight	Approx. 660g	

Performance

MASPRO

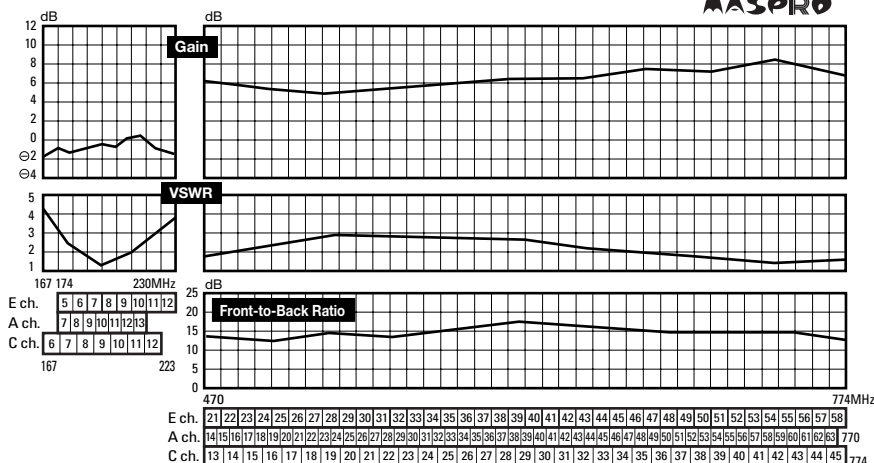

All graphs are produced using MASPRO's original, fully-automatic antenna measuring device. MASPRO's performance data is obtained with painstaking honesty and is completely reliable. MASPRO guarantees the accuracy of its performance data.

Directivity

Directivity is indicated by front-to-back ratio and beam width.

Half Power Beam Width

- The narrower the beam width,
- The less likely it is that the antenna will generate interference through reflected signals from the front.
 - The higher the actual gain produced.

Front-to-Back Ratio

Front-to-back ratio is the ratio of the forward and backward sensitivity in dB. The larger the front-to-back ratio, the less likely it is that the antenna will generate interference through reflected signals from the back.

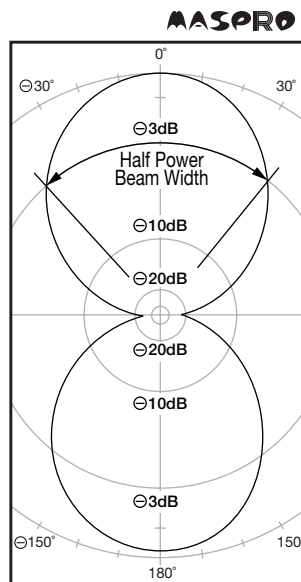

E ch. 9 Half Power Beam Width 80°

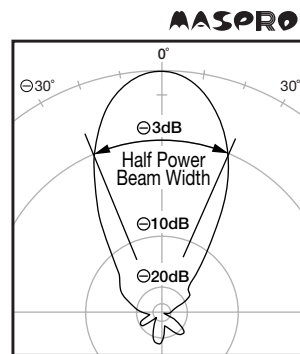

E ch. 40 Half Power Beam Width 46°

Specifications and external design are subject to change for further improvements.

=MASPRO DENKOH CORP.=

ASADA, NISSHIN, AICHI 470-0194, JAPAN



=MASPRO LANKA (PRIVATE) LIMITED=

155, U.D.A. INDUSTRIAL ESTATE, KATUWANA ROAD, HOMAGAMA, SRI LANKA

TEL : 0094-11-2895584 FAX : 0094-11-2855572

JUL., 2011